



Optimal Solutions for the Future

Lynx 220Y series



**Y axis added 6 inch /
8 inch Compact
Turning Center**

Lynx 220Y series

Lynx 220YA / YC
Lynx 220LYA / LYC
Lynx 220LSYA / LSYC

ver. EN 160718 SU

Basic Information

Structure
Cutting
Performance

Detailed Information

Standard / Options
Applications
Diagrams
Specifications

Customer Support Service



Lynx 220Y series

Lynx Y series is a new model with additional Y axis on the existing Lynx models and enables to complete complex machining using only one setup. Easy and high precision off-center machining is possible and the productivity has been highly improved through outstanding reduction of both cutting time and non-cutting time for complex shapes machining.



Contents

02 Product Overview

Basic Information

04 Structure

07 Cutting Performance

Detailed Information

08 Standard / Option

10 Applications

12 Diagrams

20 Specifications

22 Customer Support Service

Various customer parts with Y axis complex machining



Easy machining of complex shapes with One setup

Additional Y axis and sub spindle help to make machining of parts with diverse and complex shapes faster and easier

High productivity through minimizing non-cutting time

Fast, accurate and high rigidity roller type LM guides are applied on the all axes and quick rotation of turret with servo driven indexing motor maximize the productivity.

Enhanced user-friendliness for easier and more efficient product operation

User-friendly operation panel configurations, EZ Guide i and EOP(Easy Operation Package) can make easy and comfortable to use various features of the product

Structure

Stable high rigidity bed structure and application of roller type LM guide for all axes realize continued high rigidity and high accuracy of the machine

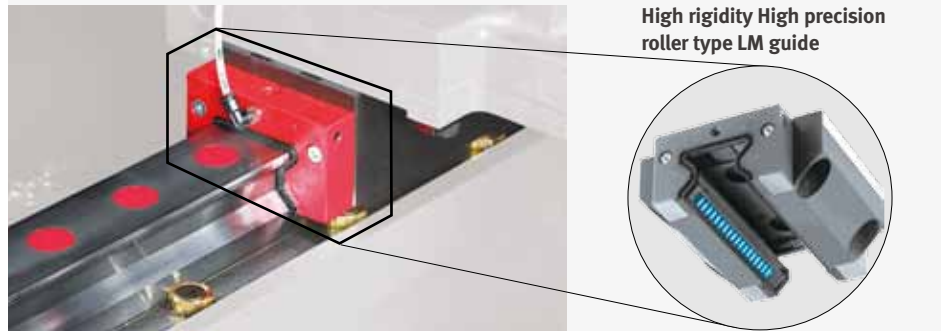
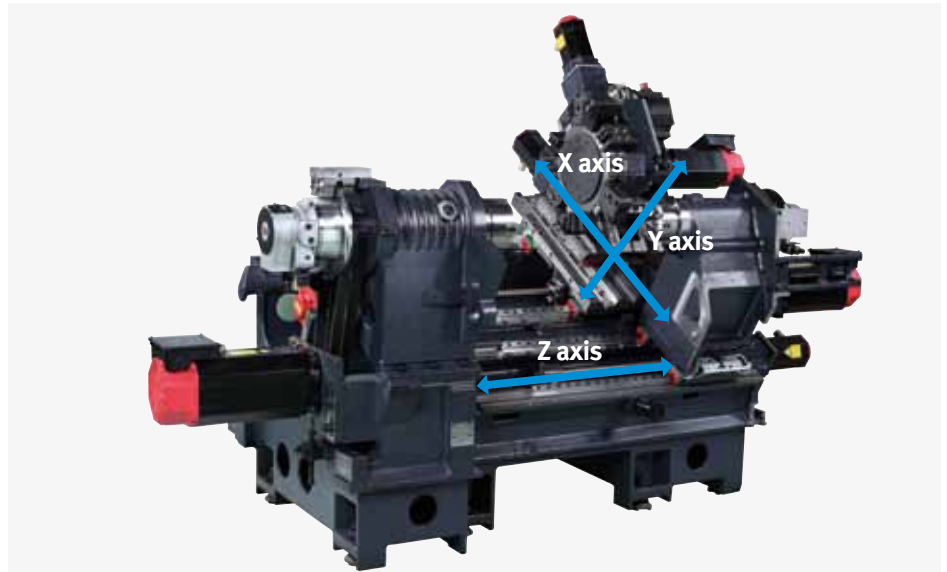

Model	Chuck size	Travel distance			Rapid traverse		
		X axis	Y axis	Z axis	X axis	Y axis	Z axis
Lynx 220YA / YC	6 / 8 inch	205 mm (8.1 inch)	105 mm (±52.5 mm) (4.1 inch (±2.05 inch))	350 mm (13.8 inch)	30 m/min (1181 ipm)	10 m/min (394 ipm)	36 m/min (1417 ipm)
Lynx 220LYA / LYC				560 mm (22 inch)			
Lynx 220LSYA / LSYC				560 mm (22 inch)			

Machining area & Variation

Lynx 220Y series offers 3 models depending on the difference of turning length and the presence or absence of sub spindle

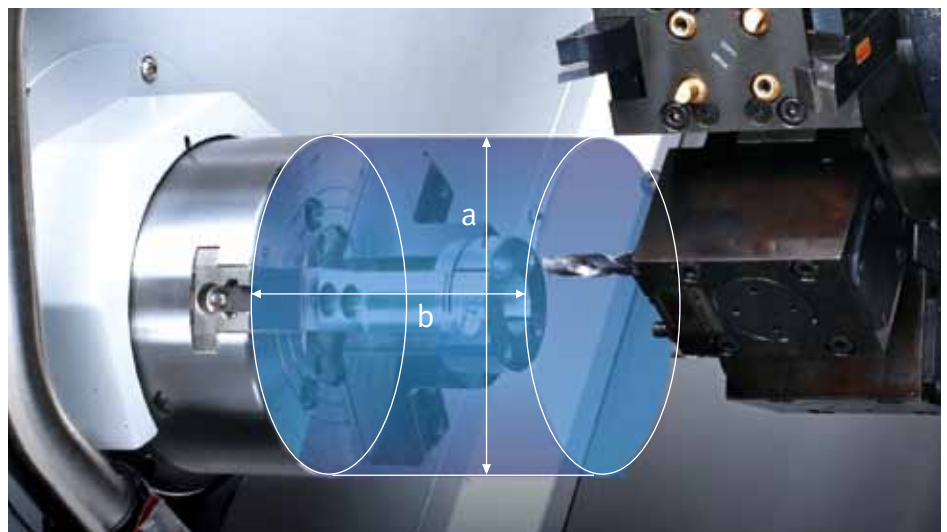

Model	Max. Turning diameter(a)	Max. Turning length(b)	Sub spindle
Lynx 220YA / YC	300 mm* (11.8 inch)	300 mm (11.8 inch)	X
Lynx 220LYA / LYC		510 mm (20.1 inch)	X
Lynx 220LSYA / LSYC		510 mm (20.1 inch)	O

* Max. Turning diameter is 236 mm in case that optional 16 station turret is mounted

High performance Y axis complex machining

Free operation in all directions of the rotary milling tool using Y axis control perform a variety of complex shape machining easily with high accuracy

Y axis Travel

105(±52.5)mm
(4.1 (+-2.05) inch)

Y axis Rapid Traverse

10m/min
(394 ipm)

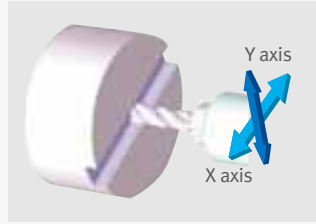

On-center face groove

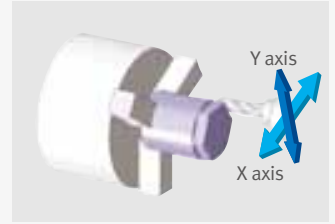

Poly-side machining

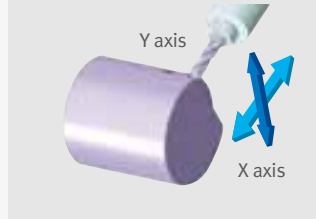

Off-center side groove



X&Y axis circular interpolation

Multi-tasking functions

Combined functions of spindle, sub spindle, Y axis and milling realize two or more general machines' manufacturing productivities

Reduced production lead time

25%



Workpiece : Machinery Component
Material : Aluminum (AL7075)
Workpiece size : Ø70 x 35 mm
Cutting tool : 16 set

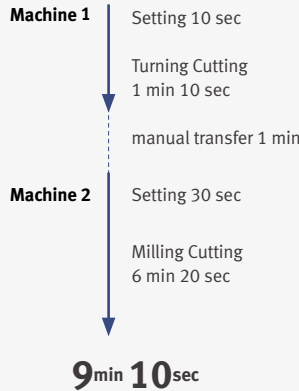

* Cutting time curtailment : Tool change time & Rapid traverse rate Calculation

Lynx Series added with SY-axis, enabling One Set-up
Save time, reduce labor, high accuracy !

2 set-up / 2 operators

1 set-up / 1 operator



Spindle

DOOSAN's best-in-class high performance spindle allows heavy duty machining of large diameter parts as well as high speed high precision machining

Main Spindle

Powerful spindle motor is capable of 0.001 degree high accuracy C axis control and can provide large bar diameter capacity until 65 mm bar working diameter.

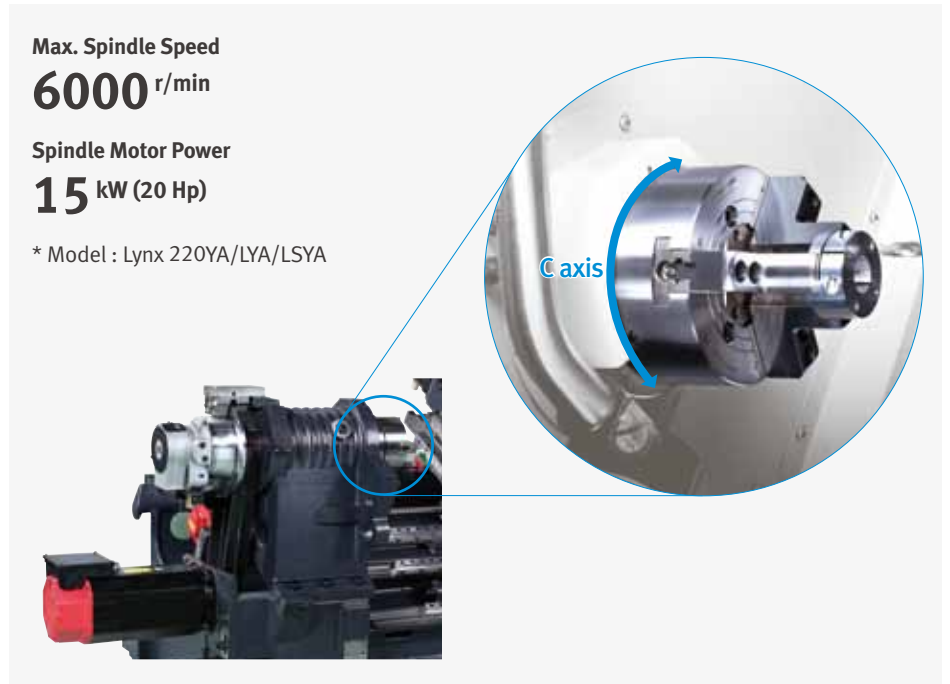

Max. Spindle Speed
6000 r/min

Spindle Motor Power
15 kW (20 Hp)

* Model : Lynx 220YA/LYA/LSYA

Model	Max. spindle speed	Spindle motor power	Max. spindle torque
Lynx 220YA / LYA / LSYA	6000 r/min	15 kW (20 Hp)	127 N·m (94 lbf ft)
Lynx 220YC / LYC / LSYC	4500 r/min	15 kW (20 Hp)	169 N·m (125 lbf ft)

Sub Spindle (Lynx 220LSYA / C)

C axis synchronization between main spindle and sub spindle is possible and various machining functions including turning, milling and cutting on the sub spindle can be performed using a single set up

Max. sub spindle speed
6000 r/min

Min. C axis indexing angle
0.001 deg.(360 degree indexing).



Tailstock(Lynx 220LYA / C)

Widely spaced guideways and heavy-duty design of the tailstock body ensure outstanding rigidity and precision. In particular, the programmable type tailstock offers EZ function* for automatic work piece location setting.

Quill bore taper
MT#4

Convenience Features
EZ function* option

* available at the programmable type tailstock only



Turret

Servo driven indexing raise the reliability and BMT type milling turret ensures high rigidity.

Servo driven Turret

High torque servo motor controls rotational acceleration and deceleration of turret and clamping/unclamping operations and its excellent dividing position brings continual high machining accuracy.





<p>Number of Tool stations</p> <p>12^{ea} (16ea <small>option</small>)</p> <p>Indexing time (1 station swivel)</p> <p>0.11^s</p>	 <p>12station Turret</p>	 <p>16station Turret</p>
---	--	---

Servo driven Turret

High torque servo motor controls rotational acceleration and deceleration of turret and clamping/unclamping operations and its excellent dividing position brings continual high machining accuracy.

<p>Max. Rotary Tool Speed</p> <p>6000 r/min</p>	
---	---

Cutting Performance

OD turning (turning dia. 88 mm (3.5 inch))				
Cutting speed	Feedrate	Cutting depth	Chip removal rate	
210 m/min (8268 ipm)	0.5 mm/rev (0.02 ipr)	4 mm (0.16 inch)	399 cm ³ /min (24.3 inch ³ /min)	
U-drilling (2 axis)				
U drill dia.	Spindle speed	Cutting speed	Feedrate	
Ø 63 mm (2.5 inch)	1011 r/min	200 m/min (7874 ipm)	0.15 mm/rev (0.006 ipr)	
Drilling				
Tool dia.	Milling spindle speed	Cutting speed	Feedrate	
Ø 12 mm (0.5 inch)	3184 r/min	120 m/min (4724 ipm)	0.20 mm/rev (0.008 ipr)	
Endmill				
Tool dia.	Cutting speed	Feedrate	Cutting depth	
Ø 12 mm (0.5 inch)	60 m/min (2362 ipm)	300 mm/rev (11.8 ipr)	14 mm (0.6 inch)	
Tapping				
Tool	Milling spindle speed	Cutting speed	Feedrate	
M14 X P1.75	387 r/min	17 m/min (669 ipm)	1.75 mm/rev (0.07 ipr)	

* The results, indicated in this catalogue are provides as example. They may not be obtained due to differences in cutting conditions and environmental conditions during measurement.



Standard / Optional Specifications

● Standard ○ Optional X N/A

Diverse optional devices and features are available to meet specific customer requirements.

Basic Information

Structure
Cutting
Performance

Detailed Information

Standard / Options
Applications
Diagrams
Specifications

Customer Support Service

NO.	Description	Features	Lynx 220YA	Lynx 220YC	Lynx 220LYA	Lynx 220LYC	Lynx 220LSYA	Lynx 220LSYC
1	Chuck	6 inch	●	X	●	X	●	X
2		8 inch	○	●	○	●	○	●
3		10 inch	X	○	X	○	X	○
4		No chuck	○	○	○	○	○	○
5		5 inch (for sub spindle)	X	X	X	X	●	●
6	Jaw	Soft jaw	●	●	●	●	●	●
7		Hard jaw	○	○	○	○	○	○
8	Chucking Option	Dual pressure chucking	○	○	○	○	○	○
9		Chuck clamp confirmation	○	○	○	○	○	○
10	Tailstock	Manual	X	X	●	●	X	X
11		Programmable	X	X	○	○	X	X
12	Coolant Pump	1.5 bar	●	●	●	●	●	●
13		Increase Power (4.5/7/10/14.5/20 bar)	○	○	○	○	○	○
14	Coolant options	Chuck coolant	○	○	○	○	○	○
15		TSC for sub spindle	X	X	X	X	○	○
16		Coolant chiller	○	○	○	○	○	○
17		Oil skimmer	○	○	○	○	○	○
18		Coolant pressure switch	○	○	○	○	○	○
19		Coolant level switch	○	○	○	○	○	○
20		Coolant gun	○	○	○	○	○	○
21	Chip disposal options	Side type chip conveyor	○	○	○	○	○	○
22		Rear type chip conveyor	○	○	○	○	○	○
23		Chip bucket	○	○	○	○	○	○
24		Air blower	○	○	○	○	○	○
25		Mist collector interface	○	○	○	○	○	○
26		Integrated mist collector	○	○	○	○	○	○
27	Measuring & automation	Tool setter (manual/automatic)	○	○	○	○	○	○
28		Part catcher with parts box	○	○	○	○	○	○
29		Part catcher with parts conveyor	○	○	○	○	○	○
30		Workpiece ejector	X	X	X	X	○	○
31		Auto door	○	○	○	○	○	○
32		Bar feeder interface	○	○	○	○	○	○
33		Robot interface	○	○	○	○	○	○
34	Others	Tool load monitoring system	○	○	○	○	○	○
35		Linear scale	○	○	○	○	○	○
36		Signal tower	○	○	○	○	○	○
37		Air gun	○	○	○	○	○	○
38		Automatic power off	○	○	○	○	○	○

Oil skimmer option

The oil skimmer keeps coolant and lubricant isolated from each other for extending life cycle of coolant.



Tool setter option

The tool setter facilitates setting of tools, and fast and precise length compensation of worn tools



Mist collector option

The mist collector absorbs airborne oil vapor and fine dusts in the system to improve working environment.



Chip conveyor option



Chip conveyor type	Material	Description
Hinged belt	Steel	Most typical type of chip conveyor. Appropriate for steel materials generating chips of length of 30 mm or more.
Screw	Steel	Chip conveyor with smallest footprint. Demands 80% of footprint comparing to hinged belt.
Magnetic scrapper	Cast iron	Chip conveyor with magnet equipped: Appropriate for cast iron workpieces generating fine chips.

Part catcher option

The part catcher automatically accepts parts completed of machining, and ejects them out of the system.



Coolant system

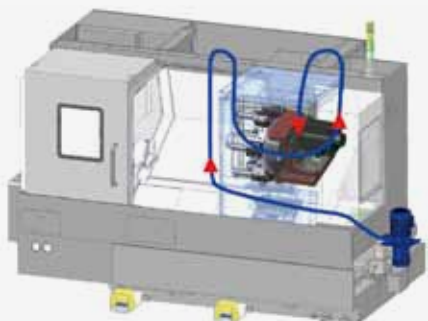

Coolant pump	Output pressure (bar)	std./opt.
Pump1	1.5	std.
Pump2	4.5	opt.
Pump3	7	
Pump4	10	
Pump5	14.5	
Pump6	20	

Coolant chiller option

Detachable coolant chiller is recommended to keep thermal error minimal and get higher machining precision.

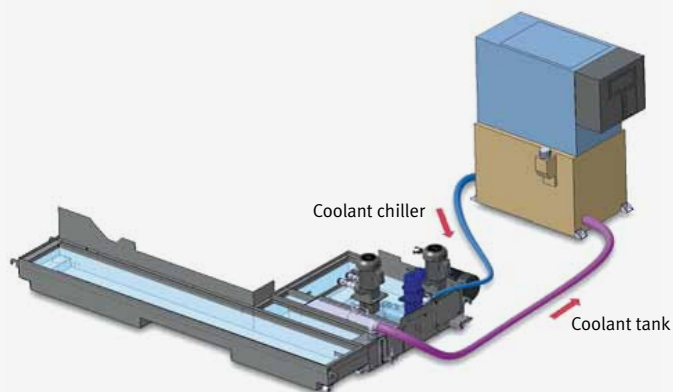



DOOSAN-FANUC i

Apply Fanuc CNC on the Doosan machine to fulfill best performance and productivity

User-friendly OP Panel

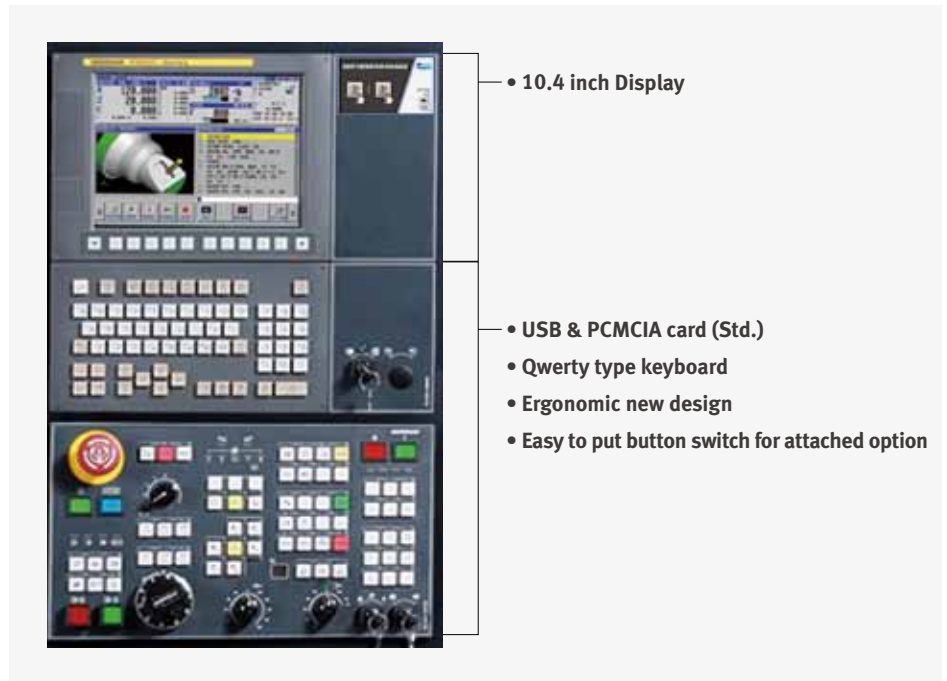

EZ-Guide i

Using the DOOSAN EZ-Guide i, users can create a cutting program for any desired shape, including patterns, by entering figures only.

Exemplary programming

Exemplary cutting shape

EZ-Guide i screen

Enter the dimensions of the shape.

Automatic creation of cutting program

```

O7000 (SAMPLE PROGRAM) ;
...
M3 S1500 ;
G0 X50. Y125. ;
G0 Z30. ;
G1040 T0.5 J3. H0.2 K0.5 ... ;
G1020 H120. V50. U37. W68. ... ;
G0 Z80. ;
M5 ;
    
```

A cutting program is automatically created with the entered values.

Productivity Improvement

Increase Productivity
 Reduced non-cutting time
 by **10%**

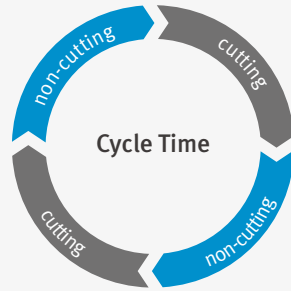

Minimizes non-cutting time to further improve productivity.

Easy Operation Package

G Code / M Code list



Operator can check the meaning of each G-code / M-code.

Calculator



Operator can calculate numerical formula in relation to arc and hole easily.

Turret maintenance and service screen



The condition and service procedures of the sensors are provided for easy maintenance and servicing of major units.

Operation rate



Function allows users to easily keep track of machine operating hours and the number of completed parts.

Tool load monitoring option



This function detects overload on tools, caused by wear and damage, and triggers an alarm to minimize damage.

Tail stock thrust force setting option

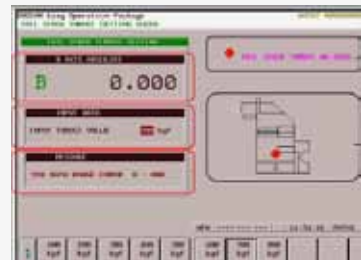

This function allows users to easily setup tailstock thrust force on the screen.

Spindle Power – Torque Diagram

Main Spindle

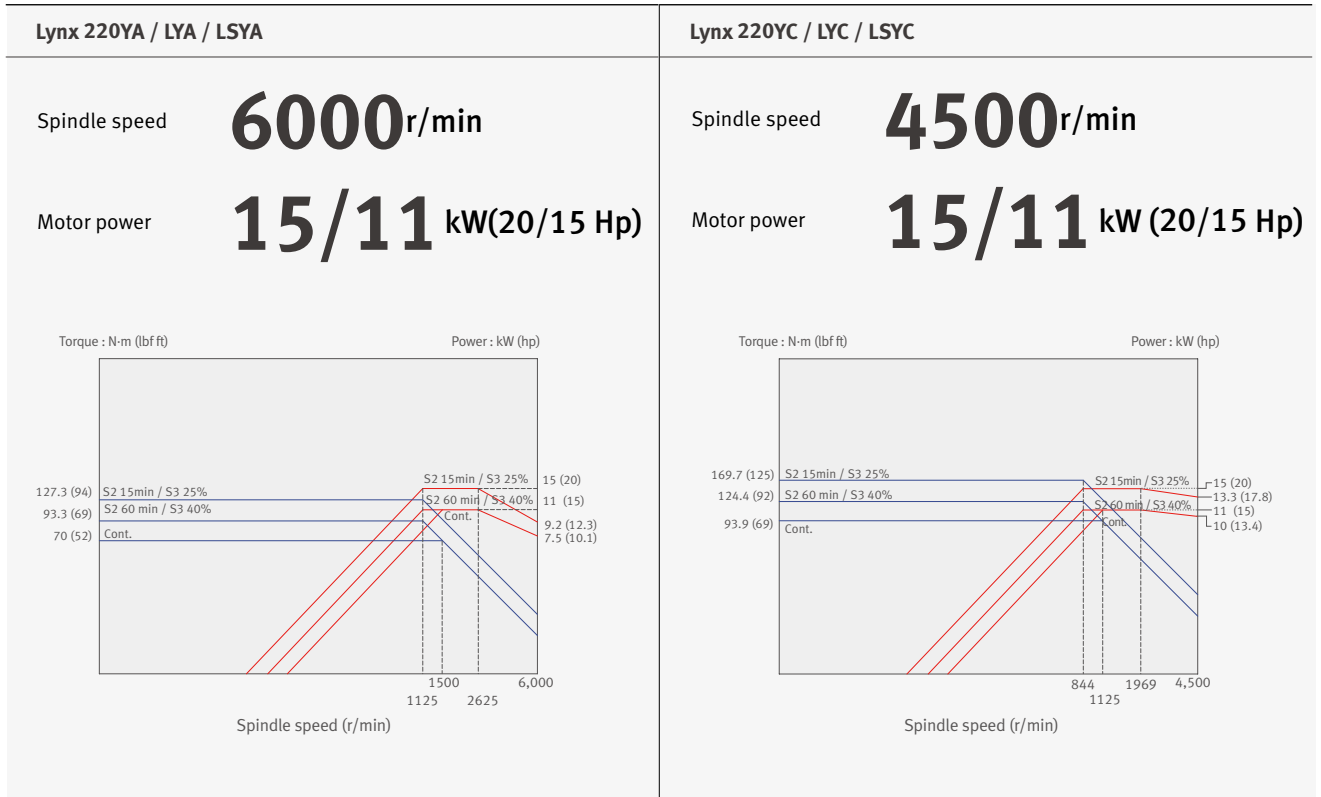

Sub Spindle

Rotary Tool Motor

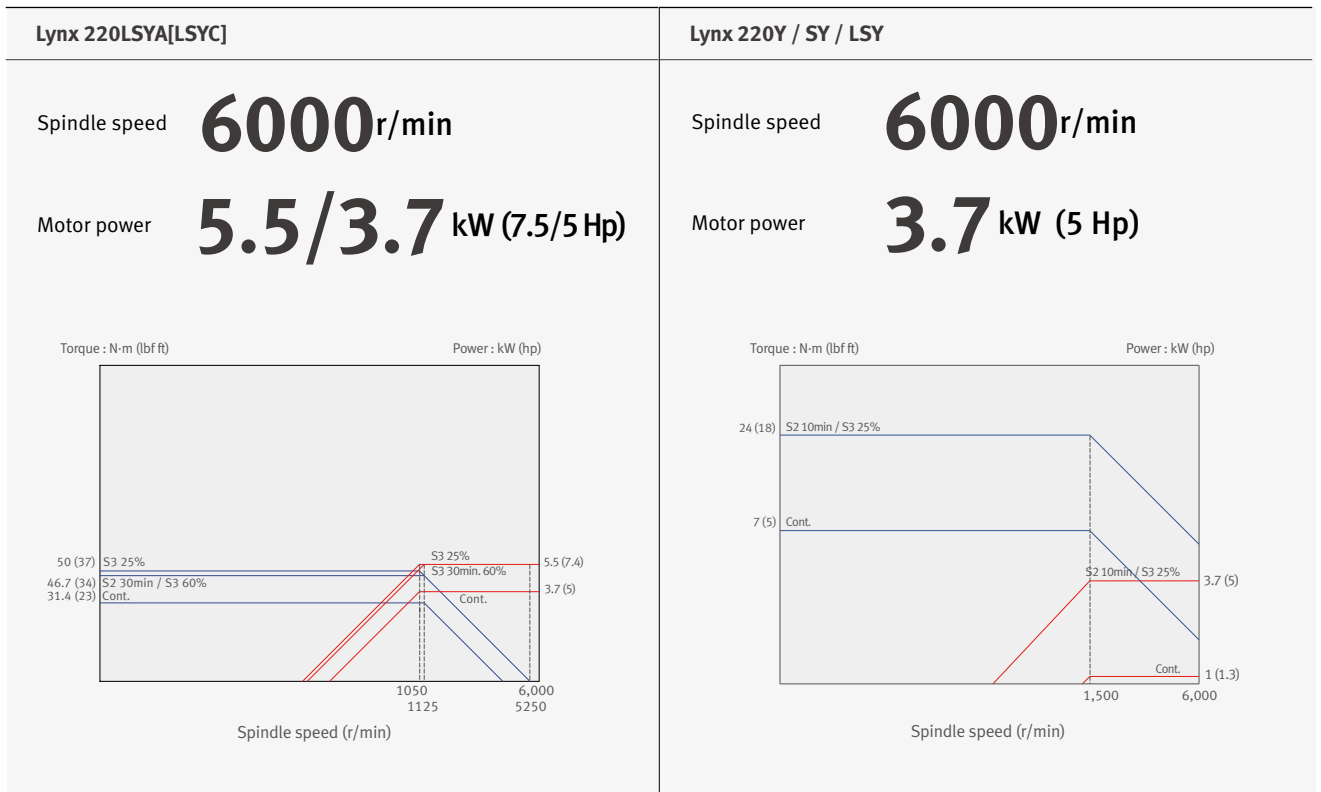

External Dimensions

Top View

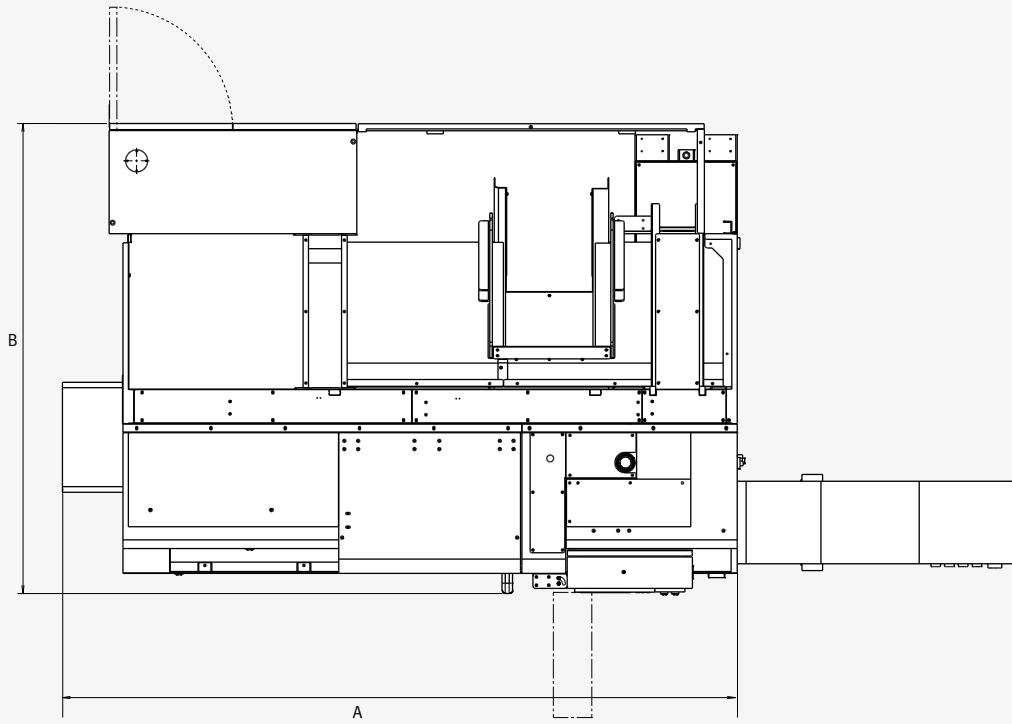

Front View

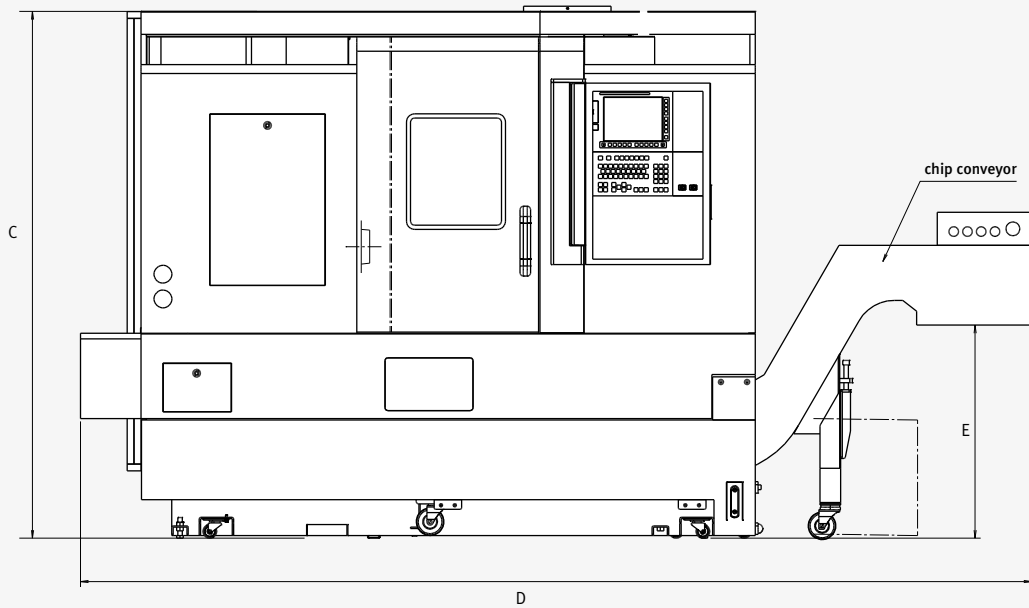

Unit: mm (inch)

	A	B	C	D*	E*
Lynx 220YA / C	2460 (96.9)	1710 (67.3)	1920 (75.6)	3459 (136.2)	775 (30.5)
Lynx 220LYA / LSYA	2850 (112.2)	1710 (67.3)	1920 (75.6)	3896(153.4)	780 (30.7)
Lynx 220LYC / LSYC	2880 (113.4)	1710 (67.3)	1920 (75.6)	3926 (154.6)	780 (30.7)

* D, E : on the basis of fitting hinged belt type chip conveyor

Tooling system

Basic Information

Structure
Cutting
Performance

Lynx 220Y / LY

Unit: mm (inch)

Detailed Information

Standard / Options
Applications
Diagrams
Specifications

Customer Support Service

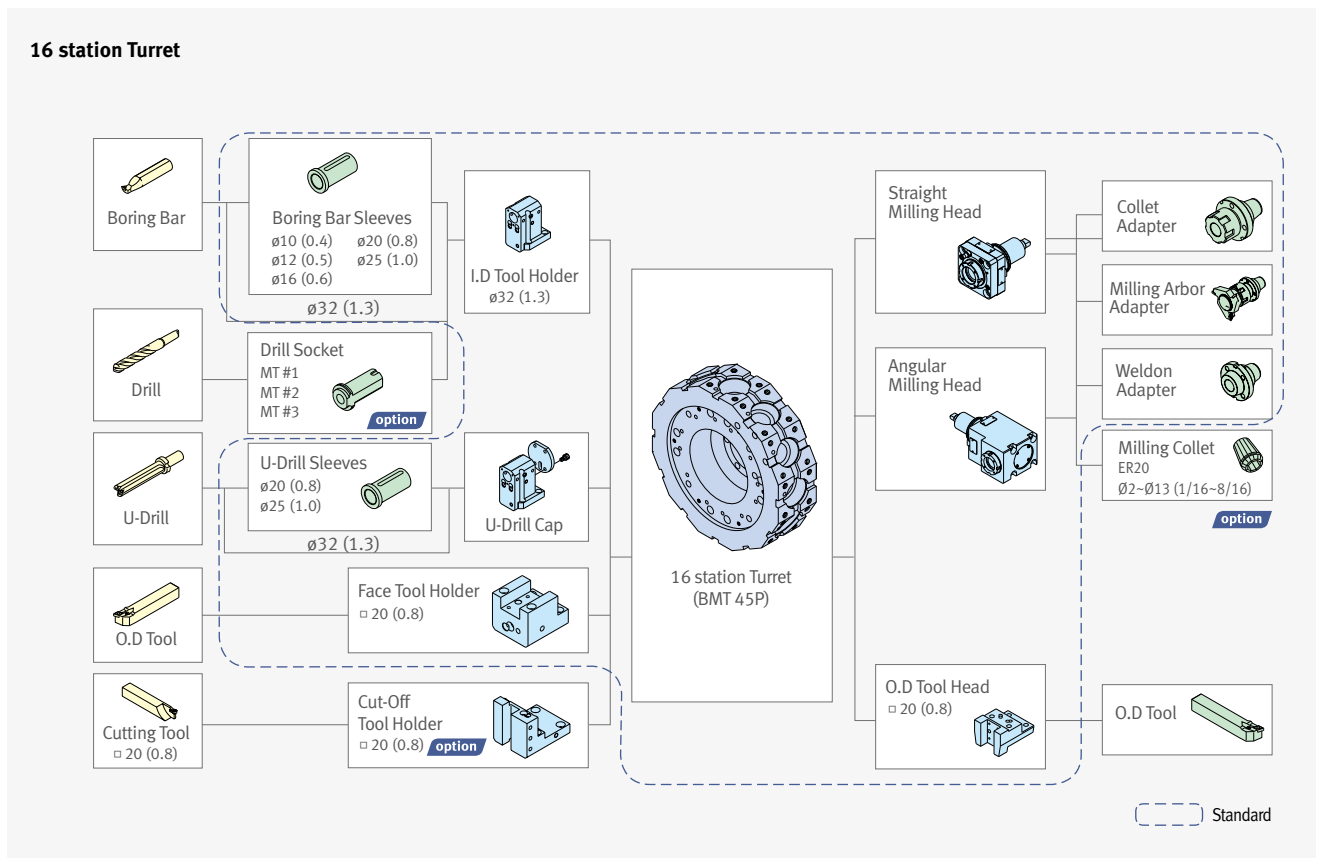
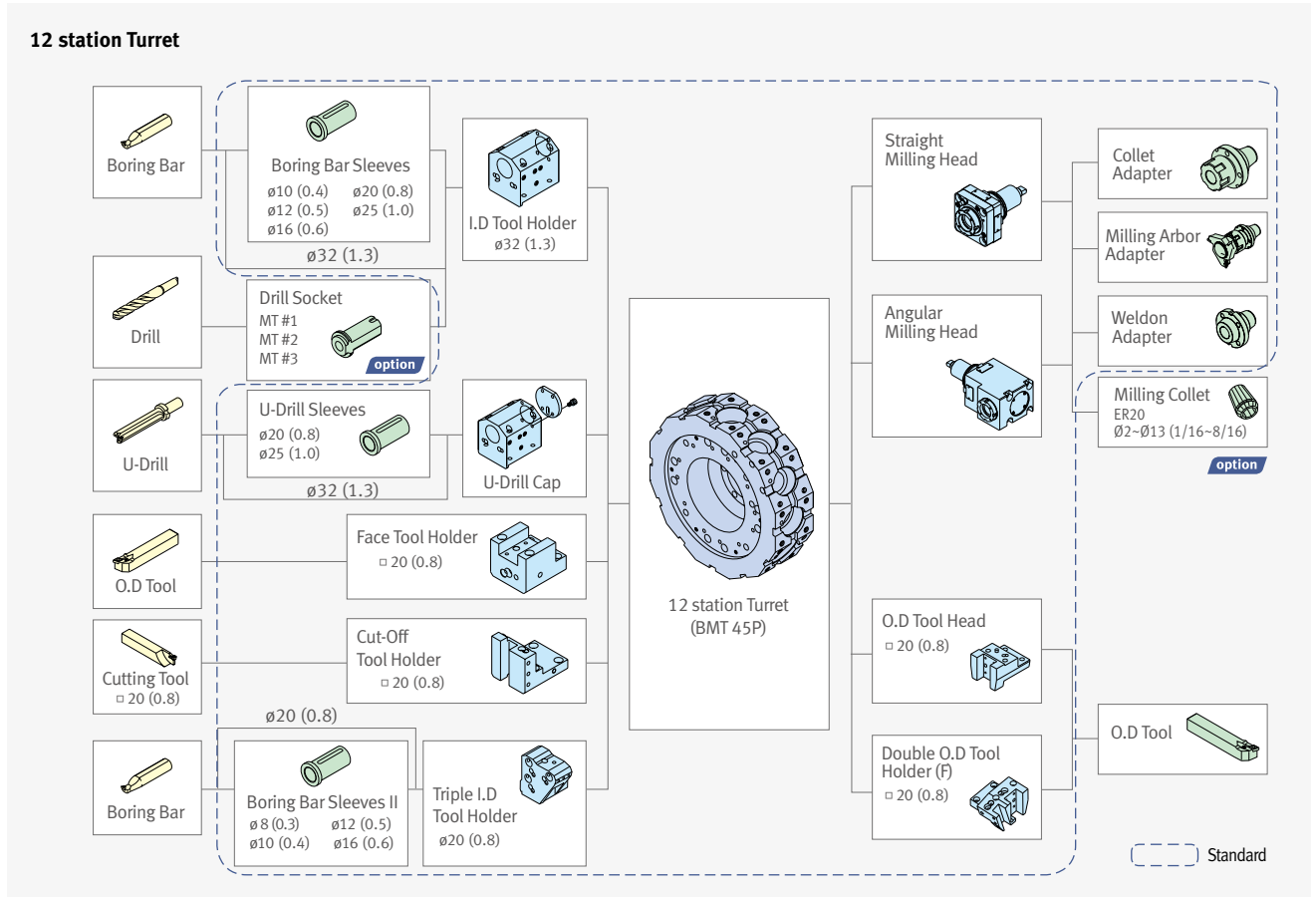

12 station Turret

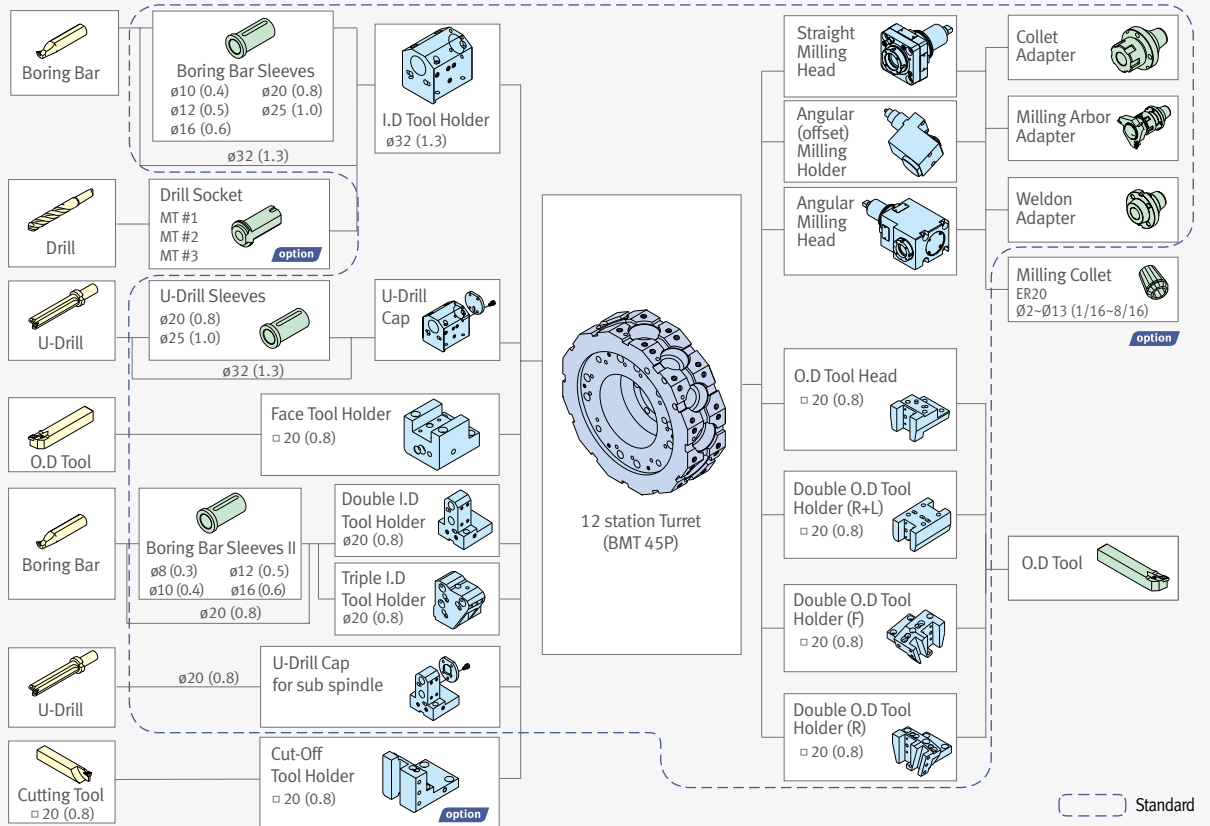

16 station Turret

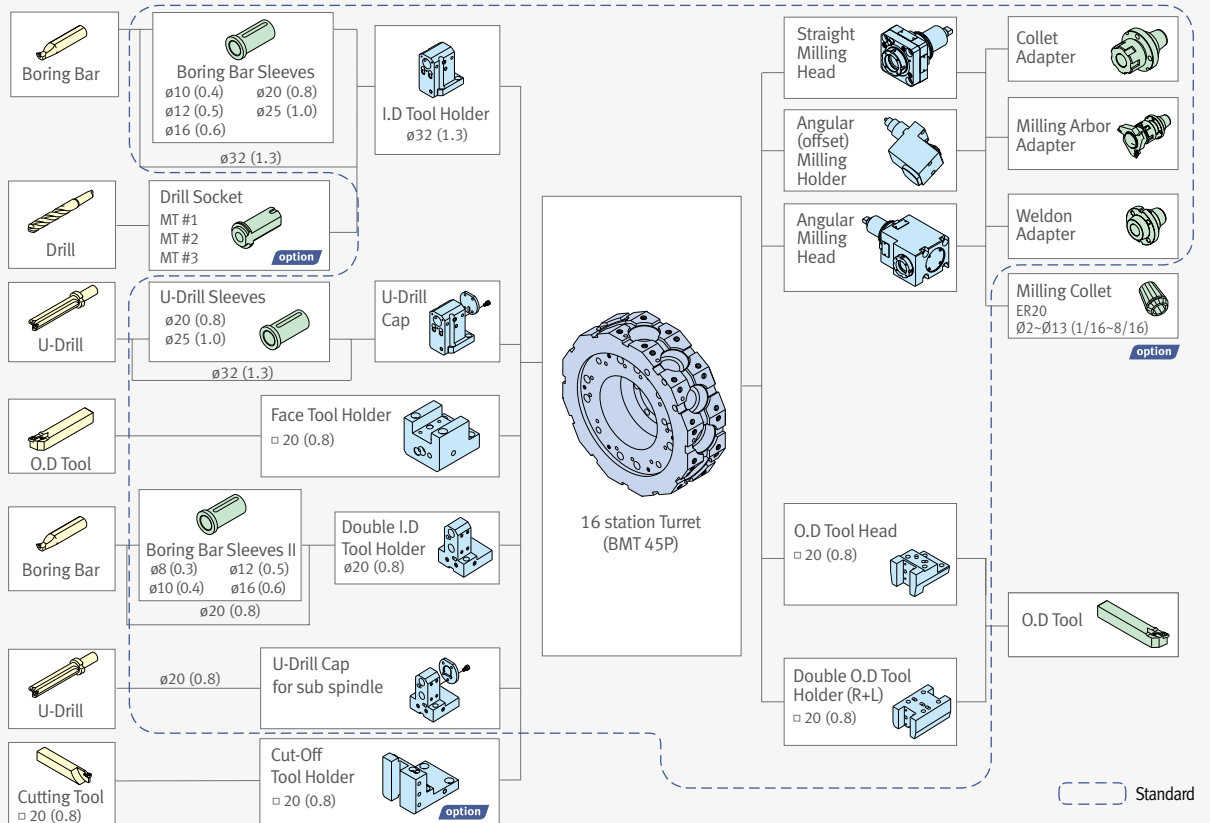

Tool interference diagram

Basic Information

Structure
Cutting
Performance

Detailed Information

Standard / Options
Applications
Diagrams
Specifications

Customer Support Service

Lynx 220Y / LY

Unit: mm (inch)

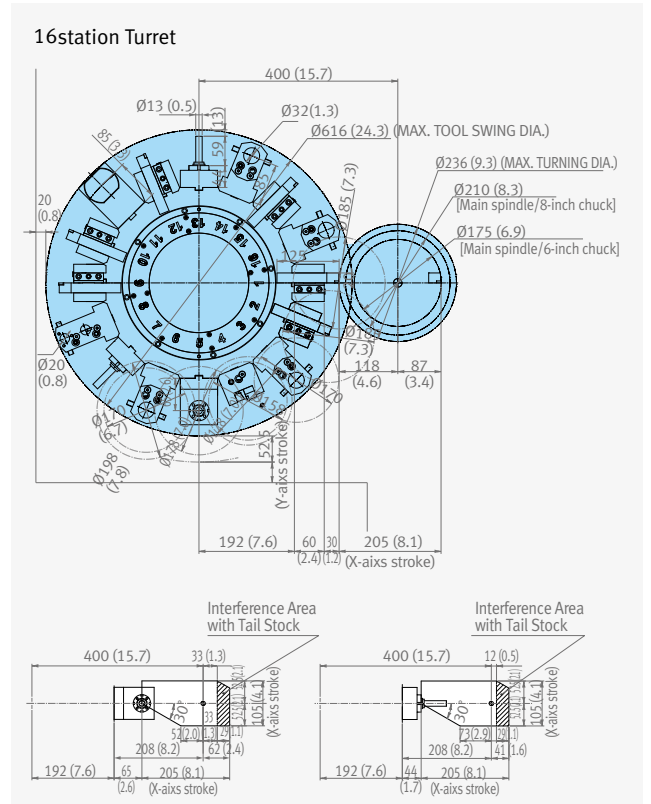
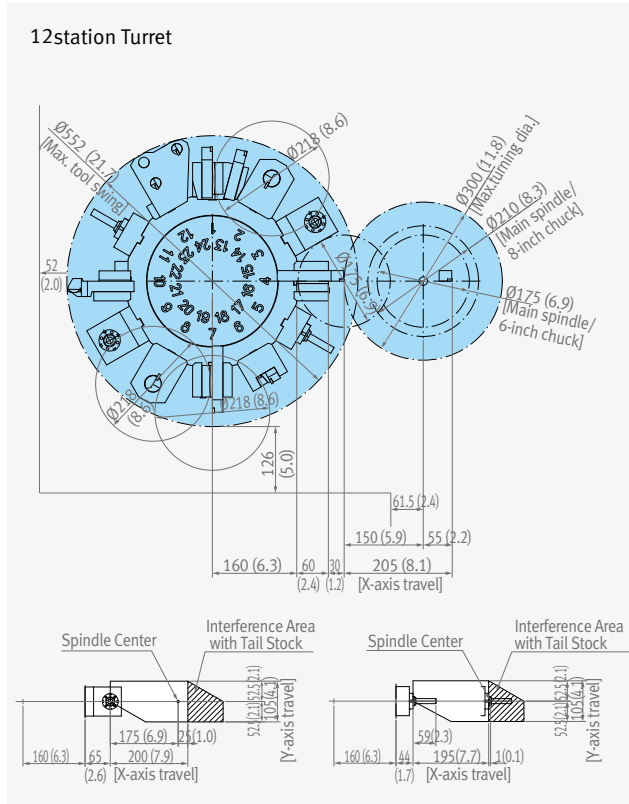

Lynx 220LSY

Unit: mm (inch)

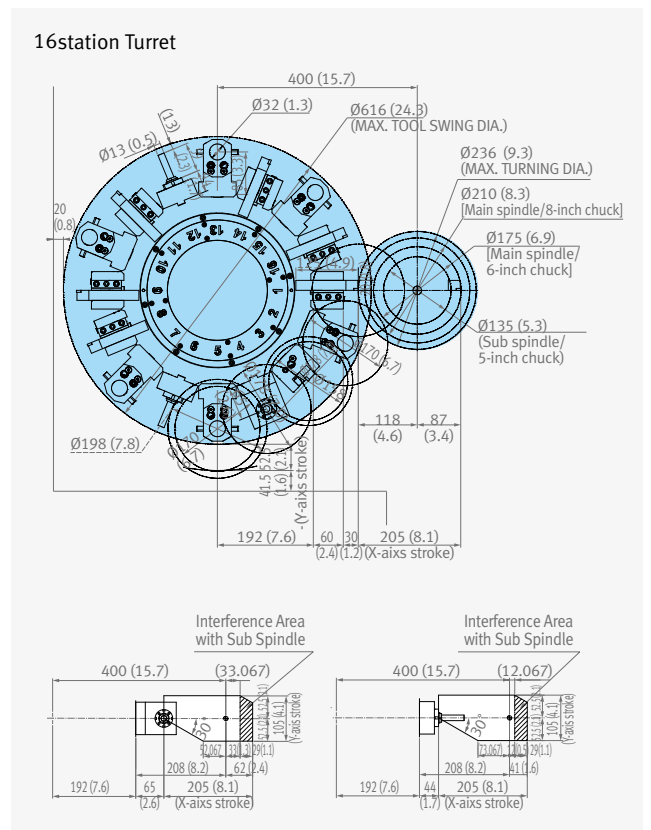
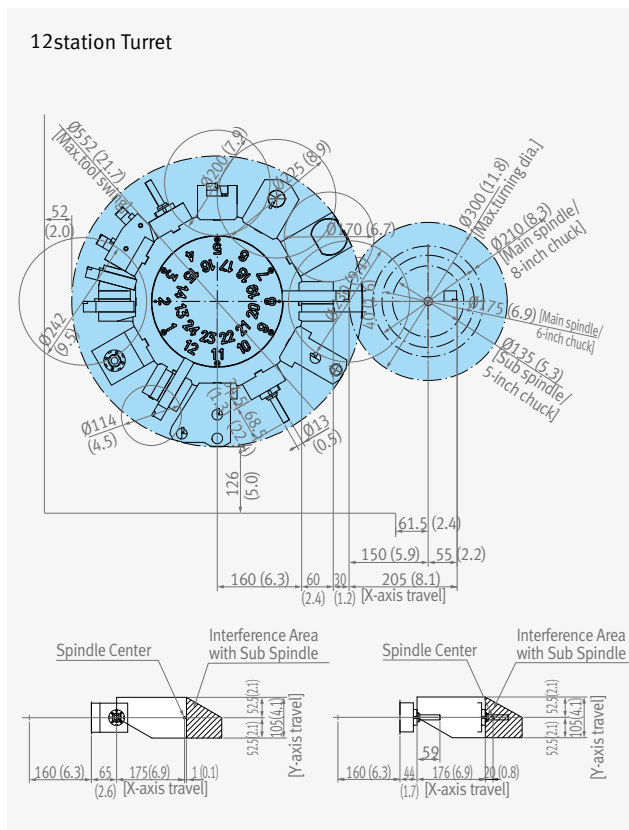

Working Range

Lynx 220LYA / LYC

Unit: mm (inch)

ID Tool

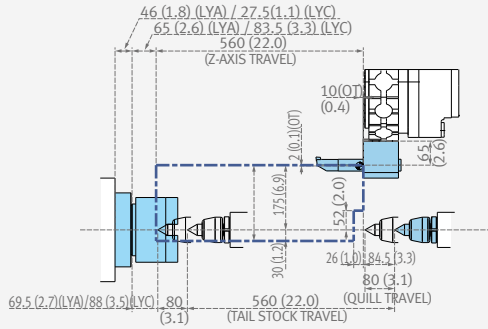

OD Tool

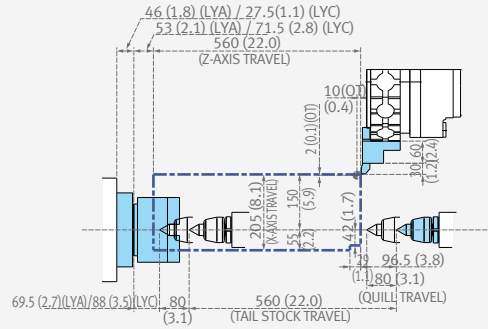

Straight Milling

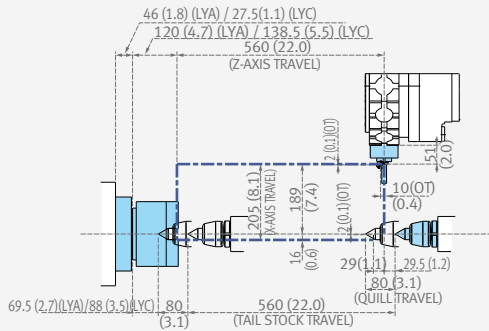

Face Tool

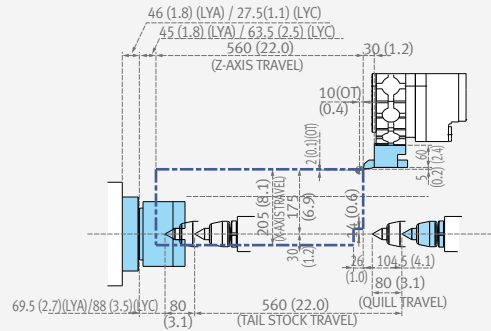

Angular Milling

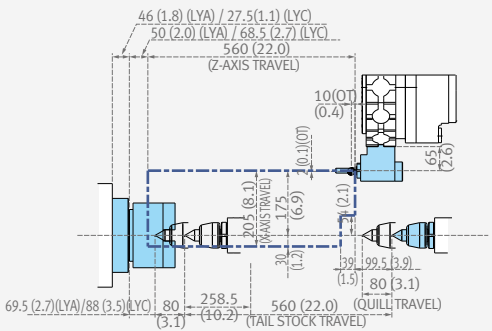

Cut Off Holder

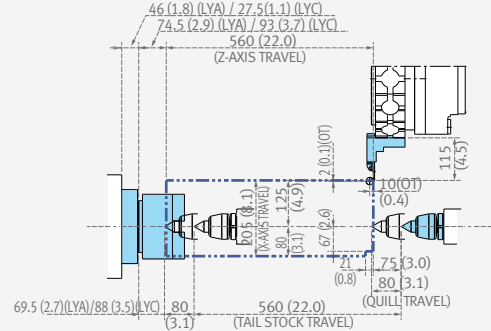

Triple ID Tool 1

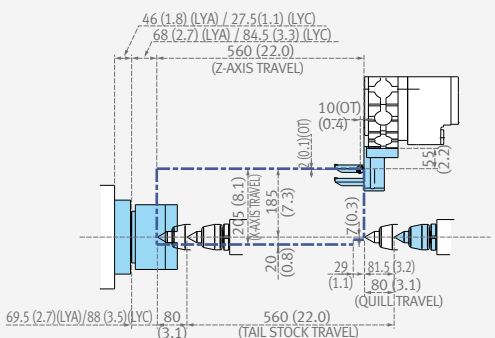

Triple ID Tool 2

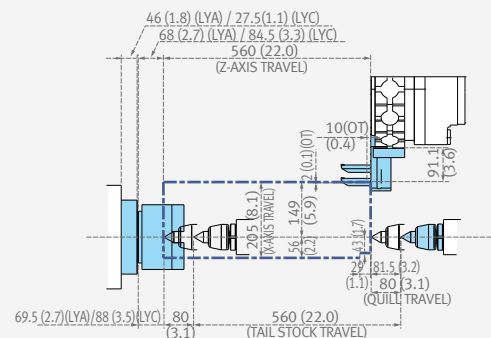

Working Range

Basic Information

- Structure
- Cutting
- Performance

Detailed Information

- Standard / Options
- Applications
- Diagrams
- Specifications

Customer Support Service

Lynx 220LSYA / LSYC

Unit: mm (inch)

ID Tool

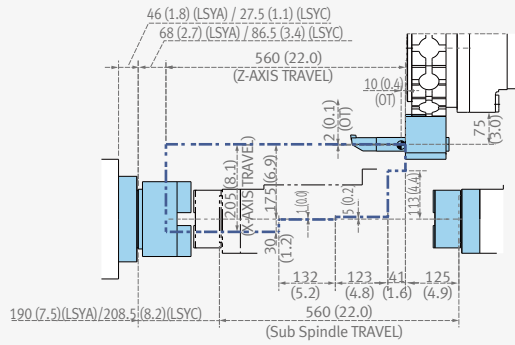

Double ID Tool

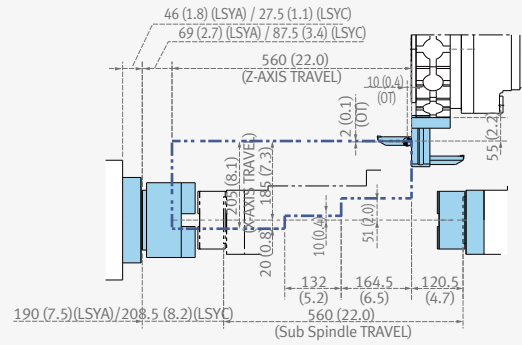

Triple ID Tool

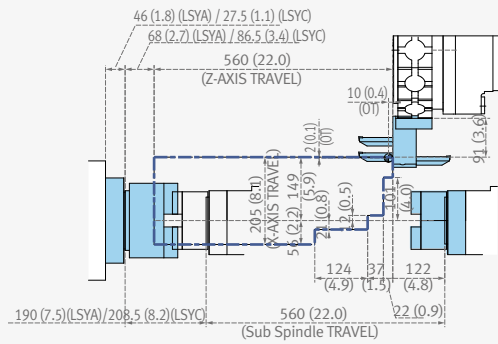

Face Tool

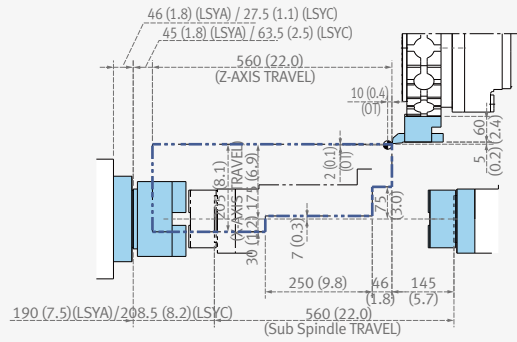

OD Tool

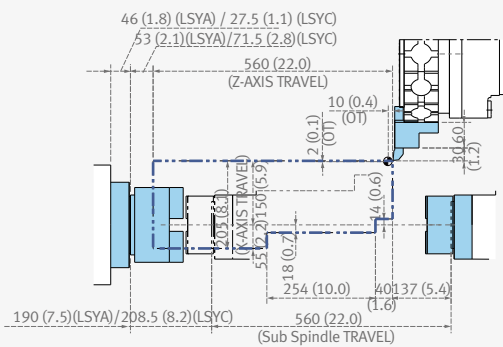

Double OD Tool [Main / Sub]

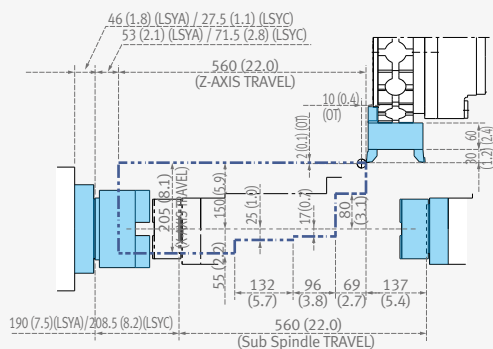

Straight Milling

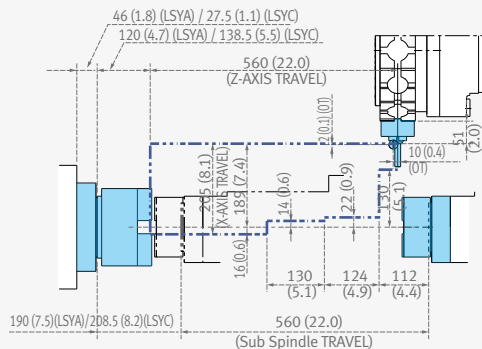

Angular Milling

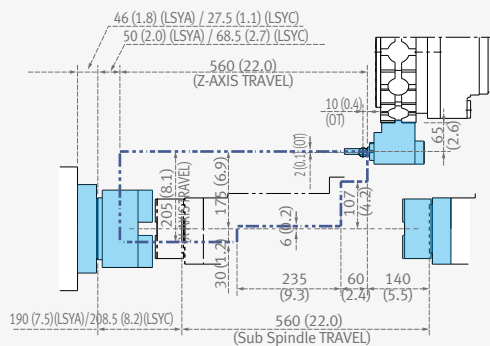

Angular Milling (offset)

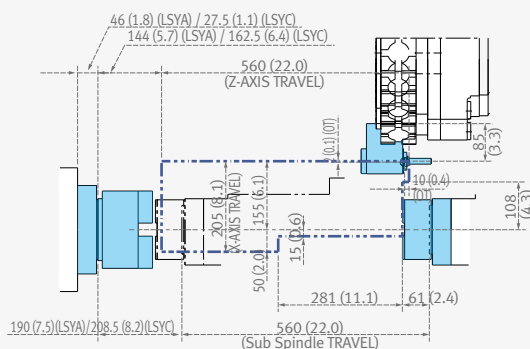

Double OD Tool (Main)

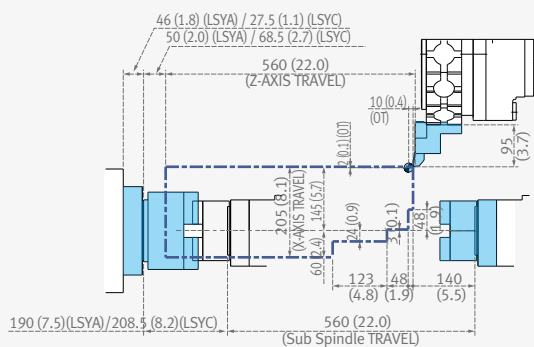

Machine specifications

Basic Information

Structure
Cutting
Performance

Detailed Information

Standard / Options
Applications
Diagrams
Specifications

Customer Support Service



Features		Unit	Lynx 220YA	Lynx 220YC	Lynx 220LYA	Lynx 220LYC	Lynx 220LSYA	Lynx 220LSYC	
Capacity	Swing over bed	mm (inch)	600 (23.6)						
	Swing over saddle	mm (inch)	400 (15.7)						
	Recom. Turning diameter	mm (inch)	170 (6.7)	210 (8.3)	170 (6.7)	210 (8.3)	170 (6.7)	210 (8.3)	
	Max. Turning diameter	mm (inch)	300 (11.8)						
	Max. Turning length	mm (inch)	300 (11.8)			510 (20.1)			
	Chuck size	inch	6	8	6	8	6	8	
	Bar working diameter	mm (inch)	51 (2.0)	65 (2.6)	51 (2.0)	65 (2.6)	51 (2.0)	65 (2.6)	
Travels	Travel distance	X-axis	205 (8.1)						
		Y-axis	105(±52.5)						
		Z-axis	350 (13.8)			560 (22.0)			
Feedrates	Rapid Traverse Rate	X-axis	30 (1181)						
		Y-axis	10 (394)						
		Z-axis	36 (1417)						
Spindle	Max. Spindle speed	r/min	6000	4500	6000	4500	6000	4500	
	Main spindle motor power	kW(Hp)	15 / 15 / 11 (20 / 20 / 15) (S3 25%/15min/Cont.)						
	Max. Spindle Torque for Turning	N·m (lbf ft)	127 (94)	169 (125)	127 (94)	169 (125)	127 (94)	169 (125)	
	Spindle nose	ASA	A2-5	A2-6	A2-5	A2-6	A2-5	A2-6	
	Spindle bearing diameter (Front)	mm (inch)	90 (3.5)	110 (4.3)	90 (3.5)	110 (4.3)	90 (3.5)	110 (4.3)	
	Spindle through hole diameter	mm (inch)	61 (2.4)	76 (3.0)	61 (2.4)	76 (3.0)	61 (2.4)	76 (3.0)	
	Min. spindle Indexing angle(C-axis)	deg	0.001						
Sub spindle	Max. Spindle speed	r/min	-				6000		
	Sub spindle motor power	kW(Hp)	-				5.5 / 5.5 / 3.7 (7.5 / 7.5 / 5) (S3 60%/30min/Cont.)		
	Max. Spindle Torque for Turning	N·m (lbf ft)	-				46 (34)		
	Spindle nose	FLAT	-				Ø110 (4.3)		
	Spindle bearing diameter (Front)	mm (inch)	-				75 (3.0)		
	Spindle through hole diameter	mm (inch)	-				43 (1.7)		
	Min. spindle Indexing angle(C-axis)	deg	-				0.001		
Turret	No. of tool stations	ea	12(24 Position Index) {16}*						
	OD tool size	mm (inch)	20 (0.8)						
	Max. boring bar size	mm (inch)	32 / 20 (1.3 / 0.8)						
	Turret Indexing time (1 station swivel)	s	0.11						
	Max. Rotary tool speed	r/min	6000						
	Rotary tool motor power	kW(Hp)	3.7 (5)						
Tailstock	Tailstock travel	mm (inch)	-			560 (22.0)		-	
	Quill diameter	mm (inch)	-			65 (2.6)		-	
	Quill travel	mm (inch)	-			80 (3.1)		-	
	Quill bore taper	MT	-			MT#4		-	
Power source	Electric power supply(rated capacity)	kVA	28.22				34.09		
Machine Dimensions	Length	mm (inch)	2460 (96.9)		2850 (112.2)	2880 (113.4)	2850 (112.2)	2880 (113.4)	
	Width	mm (inch)	1710 (67.3)						
	Height	mm (inch)	1920 (75.6)						
	Weight	kg (lb)	3500 (7700)	3600 (7920)	3850 (8470)	3900 (8580)	4150 (9130)	4150 (9130)	
CNC	NC system	DOOSAN-FANUC i							

NC unit specifications

● Standard ○ Optional X N/A

DOOSAN- FANUC i

NO.	Specification		Y/LY	LSY	
1	Controlled axis	Controlled axes	4(X,Z,C,Y)	6(X,Z,C1,Y,C2,B)	
2		Axis control by PMC	●	●	
3		Synchronous/Composite control (C1 & C2 Synchro Control)	X	●	
4		Torque control	●	●	
5		Inch/metric conversion	●	●	
6		Stored limit check before move	●	●	
7		Unexpected disturbance torque detection function	●	●	
8		Position switch	●	●	
9	Operation	DNC operation with memory card	●	●	
10		Handle interruption	○	○	
11	Interpolation functions	Manual handle retrace	○	○	
12		Nano interpolation	●	●	
13		Linear interpolation	●	●	
14		Circular interpolation	●	●	
15		Helical interpolation	●	●	
16		Thread cutting, synchronous cutting	●	●	
17		Thread cutting retract	●	●	
18		Continuous threading	●	●	
19	High-speed skip	Input signal is 8 points.	○	○	
20	feed function	2nd/3rd/4th reference position return	G30	●	●
21		AI contour control I		○	○
22		AI contour control II		○	○
23		Rapid traverse block overlap		●	●
24	Program input	Optional block skip	9 pieces	●	●
25		Absolute/incremental programming	Combined use in the same block	●	●
26		Diameter/Radius programming		●	●
27		Automatic coordinate system setting		●	●
28		Workpiece coordinate system	G52 - G59	●	●
29		Chamfering/Corner R		●	●
30		Custom macro		●	●
31		Addition of custom macro common variables	#100 - #199, #500 - #999	●	●
32		Interruption type custom macro		●	●
33		Canned cycle		●	●
34		Multiple repetitive cycles	G70~G76	●	●
35		Multiple repetitive cycles II	Pocket profile	●	●
36	Canned cycle for drilling		●	●	
37	Coordinate system shift		●	●	
38	Direct input of coordinate system shift		●	●	
39	Pattern data input		●	●	
40	Operation Guidance Function	EZ Guidei(Conversational Programming Solution)		●	●
41		EZ Operation package		●	●
42	Auxiliary/Spindle speed function	Constant surface speed control		●	●
43		Rigid tap		●	●
44	Tool function/Tool compensation	Arbitrary speed threading		○	○
45		Tool offset pairs	64-pairs	●	X
46		Tool offset pairs	99-pairs	○	X
47		Tool offset pairs	128-pairs	X	●
48		Tool offset pairs	200-pairs	X	○
49		Tool radius/Tool nose radius compensation		●	●
50		Tool geometry/wear compensation		●	●
51		Automatic tool offset	G36/G37	●	●
52	Direct input of offset value measured B		●	●	
53	Tool life management		●	●	
54	Accuracy compensation function	Backlash compensation for each rapid traverse and cutting feed		●	●
55		Stored pitch error compensation		○	○
56	Editing operation	Part program storage size & Number of registerable programs	1280M(512KB)_400 programs	●	X
57		Part program storage size & Number of registerable programs	2560M(1MB)_800 programs	X	●
58		Part program storage size & Number of registerable programs	5120M(2MB)_400 programs	○	X
59		Part program storage size & Number of registerable programs	5120M(2MB)_800 programs	X	○
60	Data input/output	Playback		●	●
61		Fast data server		○	○
62		External data input		●	●
63		Memory card input/output		●	●
64		USB memory input/output		●	●
65	Interface function	Automatic data backup		○	○
66		Embedded Ethernet		●	●
67	Others	Fast Ethernet		○	○
68		Display unit	10.4" color LCD	●	●
69	Robot interface	Robot interface with PMC I/O module		○	○
70		Robot interface with PROFIBUS-DP		○	○

Responding to Customers Anytime, Anywhere

Basic Information

- Structure
- Cutting
- Performance

Detailed Information

- Standard / Options
- Applications
- Diagrams
- Specifications

Customer Support Service

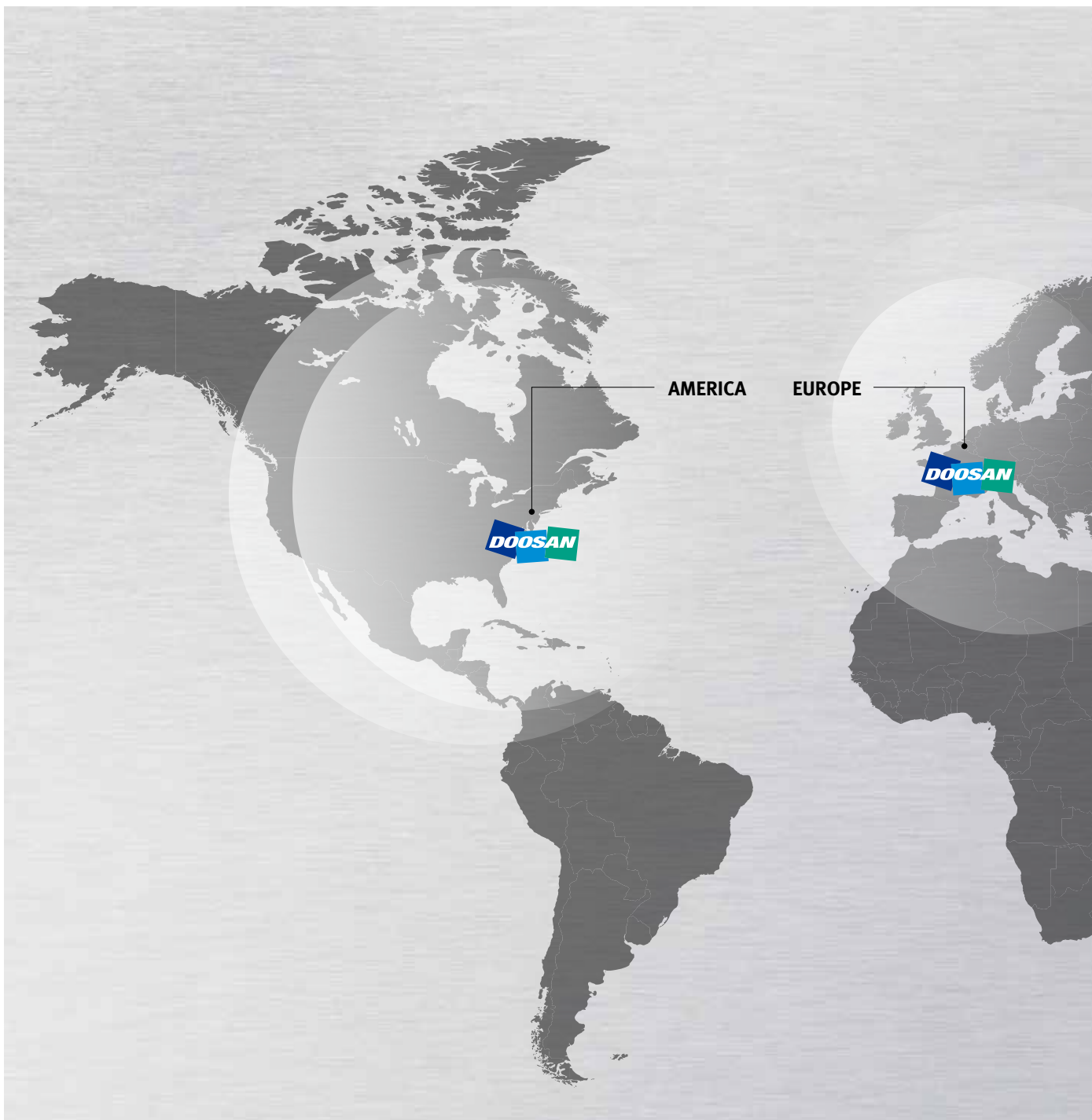

Global Service Support Network

Corporations

5

Dealer Networks

122

Technical Centers

18

Factories

3

Technical Center: Sales Support, Service Support, Parts Support

Doosan Machine Tools' Global Network, Responding to Customer's Needs nearby, Anytime, Anywhere

Doosan machine tools provides a system-based professional support service before and after the machine tool sale by responding quickly and efficiently to customers' demands.

By supplying spare parts, product training, field service and technical support, we can provide top class support to our customers around the world.



Domestic Service Support Network

Integrated Support Centers	2	Sales Branch Offices	7	Post-Sales Service Centers	6	Designated Repair Service Centers	31
----------------------------	---	----------------------	---	----------------------------	---	-----------------------------------	----

Customer Support Service

We help customers to achieve success by providing a variety of professional services from pre-sales consultancy to post-sales support.

Supplying Parts



- Supplying a wide range of original Doosan spare parts
- Parts repair service

Field Services



- On site service
- Machine installation and testing
- Scheduled preventive maintenance
- Machine repair

Technical Support



- Supports machining methods and technology
- Responds to technical queries
- Provides technical consultancy

Training



- Programming / machine setup and operation
- Electrical and mechanical maintenance
- Applications engineering

Main Specifications

Lynx 220Y



Description	UNIT	Lynx 220YA / LYA / LSYA	Lynx 220YC / LYC / LSYC
Max. turning dia.	mm (inch)	300 (11.8)	
Max. turning length	mm (inch)	300 / 510 / 510 (11.8 / 20.1 / 20.1)	
Standard chuck size	inch	6	8
Bar working dia.	mm (inch)	51 (2)	65 (2.6)
Max. spindle speed	r/min	6000	4500
Max. spindle power	kW (Hp)	15 (20)	
NC system	-	DOOSAN-FANUC I	



Doosan Machine Tools

<http://www.doosanmachinetools.com>

www.facebook.com/doosanmachinetools

Optimal Solutions for the Future

Head Office

Yeonkang Bldg., 6th FL., 270, Yeonji-dong,
Jongno-gu, Seoul, Korea
Tel +82-2-3670-5345 / 5362
Fax +82-2-3670-5382

Doosan Machine Tools China

Room 101,201,301, Building 39 Xinzhuan Highway
No.258 Songjiang District,China Shanghai(201612)
Tel +86 21-5445-1155
Fax +86 21-6405-1472

Doosan Machine Tools Japan

#2412, Mita Kokusai Bldg. 1-4-28 Mita,
Minato-ku, Tokyo 108-0073, Japan
Tel +81 3 5730 9013
Fax +81 3 5730 9016

Doosan Machine Tools America

19A Chapin Rd., Pine Brook, NJ 07058, U.S.A.
Tel +1-973-618-2500
Fax +1-973-618-2501

Doosan Machine Tools Europe

Emdener Strasse 24, D-41540 Dormagen, Germany
Tel +49-2133-5067-100
Fax +49-2133-5067-111

Doosan Machine Tools India

106 / 10-11-12, Amruthahalli, Byatarayanapura,
Bellary road, Bangalore-560 092, India
Tel +91-80-4266-0122 / 121 / 100



* For more details, please contact Doosan Machine Tools.

* The specifications and information above-mentioned may be changed without prior notice.

* Doosan Machine Tools Co., Ltd. is a subsidiary of MBK Partners. The trademark  DOOSAN is used under a licensing agreement with Doosan Corporation, the registered trademark holder.